

# Pando

INOXPAN, S.L.

FICHA TÉCNICA DE PRODUCTO

PRODUCT DATASHEET

QF-4.09

Pag: 1 de 2



## Pando PGA-4260

PRODUCTO / PRODUCT	PLACA DE COCCIÓN A GAS
CÓDIGO / CODE	PGA-4260
DESCRIPCIÓN / DESCRIPTION	PLACA GAS 610X510 - 3 FGOS.
CÓDIGO EAN / EAN CODE	8430728190479

IMAGEN\*



\* No contractual

### DATOS LOGÍSTICOS / LOGISTICAL DATA

Nº de bultos / Number of packages	1
Peso neto (kg) / Net weight	10,3 kgs
Peso bruto (kg) / Gross weight	12,3 kgs
Medidas embalaje / Packaging measures	690x580x140 mm

### ESQUEMA DIMENSIONAL / DIMENSIONAL SCHEME\*

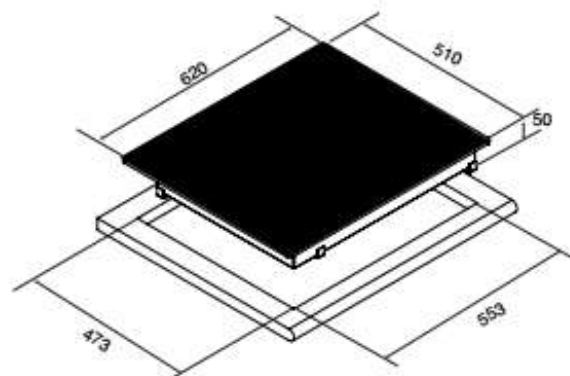

\*en mm / in mm

**CARACTERÍSTICAS TÉCNICAS / TECHNICAL CHARACTERISTICS**

<b>Alimentación / Power supply</b>	220-240 V~ / 50-60 Hz
<b>Total W</b>	1,1W
<b>Superficie de cocción Cooking Surface</b>	EUROKERA VITROCERAMIC
<b>Parrillas / Grills</b>	2x Hierro fundido negro mate 2x <i>Matte black cast iron</i>
<b>Quemadores / Burners</b>	1x quemador triple corona zona izquierda 4.0 kW 1x quemador rápido zona detrás derecha 2.8 kW 1x quemador auxiliar zona delante derecha 1.0 kW 1x <i>triple crown burner 4.0 kW</i> 1x <i>fast burner, right-rear zoned 2.8 kW</i> 1x <i>auxiliar burner, right-front zoned 1.0 kW</i>
<b>Potencia máxima Maximum power</b>	7.8 kW
<b>Instalación gas serie Predetermined gas installation</b>	Gas natural (GNC / G20) <i>Natural Gas (GNC / G20)</i>
<b>Instalación gas opcional Optional gas installation</b>	Gas butano (GLP / G30) y gas propano (GLP-31) <i>Butane gas (GLP / G30) &amp; propane gas (GLP-31)</i>
<b>Consumo gas / Gas consumption</b>	7.80 kW, (G20); 567 gr/h(G30), 557 gr/h(G31)
<b>Resistencia agua / Waterproof</b>	IPX0
<b>Otras características Other characteristics</b>	Autoencendido integrado en quemador y accionado por cada mando. <i>Integrated autoignition in burner and actuated by each control.</i>
	Dispositivo de seguridad con bloqueo automático <i>Security dispositive with automatic block</i>
	Seguridad por termopar integrada en quemador individual <i>Security by termopar integrated in each individual burner</i>